

ECCODUCT™

In-Slab Duct Ventilation System

www.eccoduct.com



ECCO™ is proud to be a member of:



SMACNA
Sheet Metal and Air
Conditioning Contractors'
National Association
www.smacna.org



HRAI
Heating, Refrigeration and
Air Conditioning
Institute of Canada
www.hrai.ca



HARDI
Heating, Air-conditioning
& Refrigeration
Distributors International
www.hardinet.org



ADI
Air
Distribution
Institute
www.steelduct.org



AD
Affiliated Distributors™
www.adhq.com



CME
Canadian
Manufacturers &
Exporters
www.cme-mec.ca



SPIDA
Spiral Duct
Manufacturers
Association
www.spida.org



INDEX

12" x 1-3/4" ECCODUCT™ FAN SIZING CHART	F1-4
ECCODUCT™	F1-5
ECCODUCT™ COMPONENTS.....	F1-3
ALUMINUM GRILLES	F1-5
DRYER BOOSTER FAN	F1-6
DUAL INLETS	F1-5
ELBOWS.....	F1-5
INCREASERS.....	F1-5
INLET BOOTS	F1-5
INSULATION.....	F1-6
LINT TRAPS — SLIM LINE	F1-6
MISCELLANEOUS.....	F1-6
SOFFIT DISCHARGES.....	F1-5
SUPPORT BRACKETS	F1-5
WALL DISCHARGES.....	F1-5
TYPICAL SPECIFICATIONS FOR IN-SLAB DUCT VENTILATION SYSTEM	F1-7

NOTE: THE ECCODUCT™ VENTILATION SYSTEM IS AN ENGINEERED SYSTEM AND MAY NOT BE AVAILABLE TO ALL WHOLESALERS.

LEGEND

NOTE: The boxed columns throughout the tables are intended to provide a quick determination of ordering dimensions.

ABBREVIATIONS:

- CTN/QTY = Carton Quantity
- WT/100 = Weight per 100 Pieces
- WT/100 FT = Weight per 100 Feet
- PCS/BNDL = Pieces per Bundle
- SKID/QTY = Skid Quantity

– E.&O.E. – Subject to Change Without Notice – May Not Be Available At All Locations –

ECCODUCT™ COMPONENTS

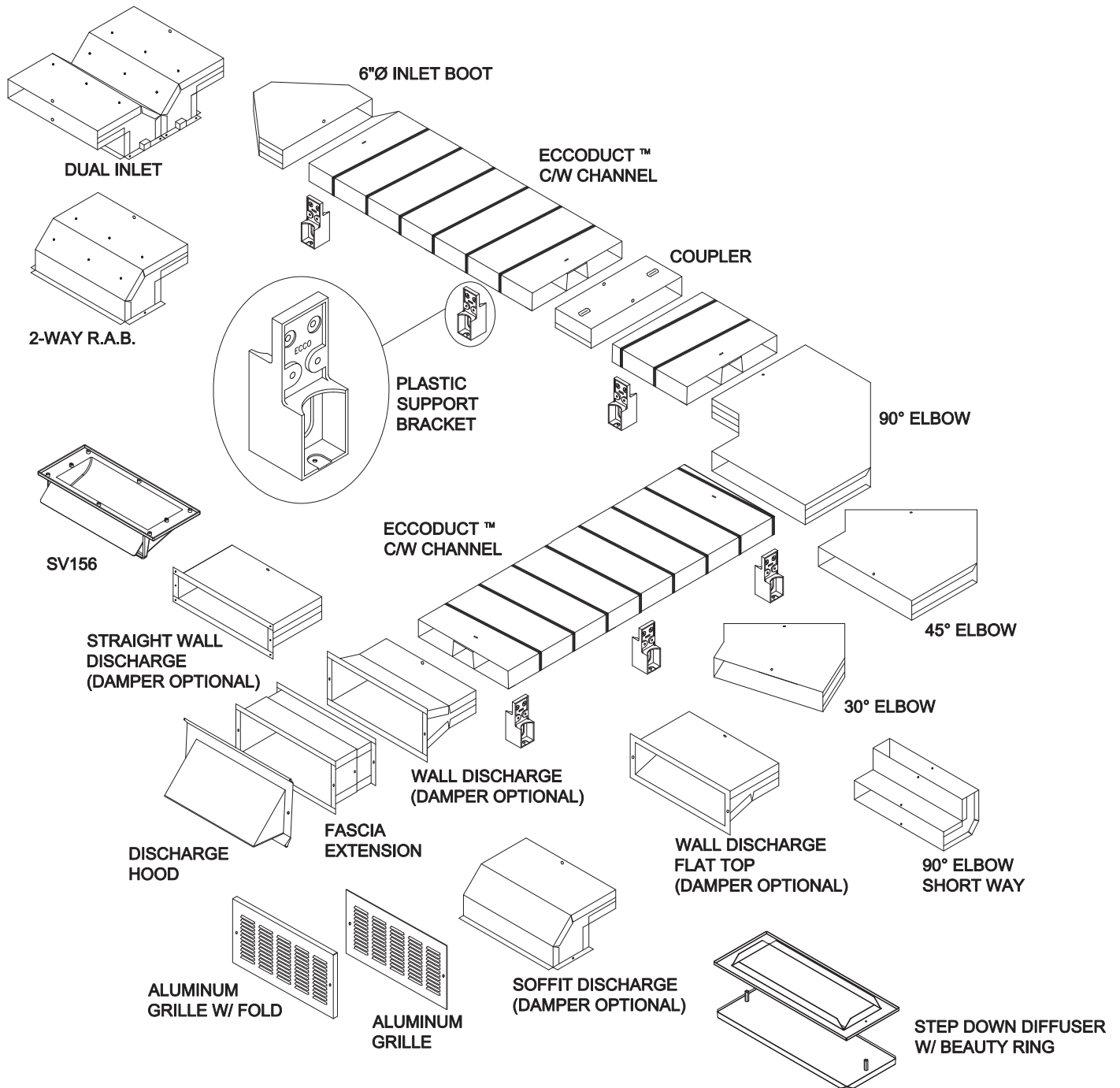

LISTED VENTILATION DUCT ASSEMBLY
 MAX 3-HR F & FT Rating
 Tested in accordance with
 ULC S115-M95 and ASTM E814-02

**SCREW AND TAPE
ALL JOINTS WITH TAPE
APPROVED BY THE ENGINEER.**

- E.&O.E. - Subject to Change Without Notice - May Not Be Available At All Locations -



12" x 1-3/4" ECCODUCT™ FAN SIZING CHART*

CFM's shown on chart are for matching fan delivery to duct system.

		Inlet Static Pressure in Inches of Water													
		.10	.15	.20	.25	.30	.35	.40	.45	.50	.55	.60	.65	.70	.75
Equivalent Feet of Duct	25	114	139	164	184	201	220	235	250	265	279	290	305	317	328
	30	100	125	148	166	184	201	214	225	240	250	262	276	285	295
	35	92	115	133	152	169	183	197	210	220	233	243	253	264	275
	40	86	107	125	142	157	170	183	195	207	216	225	234	245	255
	45	82	100	117	132	146	158	166	184	192	201	213	221	230	236
	50	76	95	111	125	139	151	162	173	183	192	201	211	220	226
	55	72	89	105	118	132	142	154	164	174	184	192	199	207	214
	60	69	86	100	113	125	135	145	155	165	175	184	192	199	205
	65	66	82	96	108	120	130	140	149	158	167	175	184	190	196
	70	63	78	92	105	116	126	136	146	154	161	169	175	182	190
	75	61	76	88	100	111	121	130	139	148	156	162	170	176	183
	80	57	70	83	96	105	114	120	126	136	144	151	159	165	170
	85	54	68	80	91	100	110	117	123	128	140	146	153	160	164
	90	52	66	77	88	96	106	114	121	126	136	140	145	154	160
	100	51	64	74	84	91	100	107	114	120	129	134	140	147	152
110	48	58	70	79	87	95	102	110	116	121	128	133	139	145	
120	46	56	66	76	84	92	98	105	112	116	120	126	133	138	
130	45	54	65	73	80	87	94	100	106	112	117	121	125	133	
140	43	53	60	71	77	84	90	96	102	108	114	117	121	126	
150	42	51	58	67	75	80	87	93	98	105	110	115	118	122	

Equivalent length of fittings:

- Inlet Boot, 26 ft.
- Wall Discharge with Damper and Grille, 6 ft.
- Soffit Discharge with Grille, 13 ft.
- 30° Elbow, 7 ft.
- 45° Elbow, 7 ft.
- 90° Elbow, 12 ft.

Example: A 100 CFM system consists of: inlet boot; 15 ft. duct; one 45° elbow and wall discharge with damper and grille. Total equivalent feet of duct equals 26 + 15 + 7 + 6 which equals 54 feet. Duct capacity required is 100 CFM, therefore, from chart, fan must deliver at least 100 CFM @ 0.20 inches of water static pressure or greater.

*Based on 4.50" equivalent round diameter.

ECCODUCT™

ITEM #	SIZE (")	DESCRIPTION	SKID/QTY	WT/100 FT
328012	12 × 1-3/4	Duct with Channel (10 ft.)	36	270

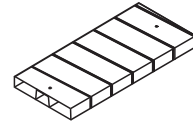

Smooth interior with reinforced channel.

ECCODUCT™ COMPONENTS
INLET BOOTS

ITEM #	SIZE (")	DESCRIPTION	CTN/QTY	WT/100
337432	12 × 1-3/4	6" Inlet Boot Firestop 2-1/8"	20	275
337435	12 × 1-3/4	6" Inlet Boot Firestop 2-3/4"	20	282
337436	12 × 1-3/4	6" Inlet Boot Firestop 3-1/4"	20	290
337332	12 × 1-3/4	5" Inlet Boot Firestop 2-1/8"	20	265
337336	12 × 1-3/4	5" Inlet Boot Firestop 3-1/4"	20	280
336812	12 × 1-3/4	2-Way Right Angle Boot Firestop – 2-1/8"	20	265
336816	12 × 1-3/4	2-Way Right Angle Boot Firestop – 3-1/4"	20	285

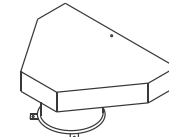

6" Inlet Boot with optional Increaser

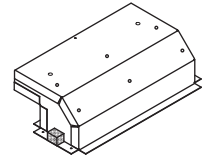

2-Way Right Angle Boot Firestop

ELBOWS

ITEM #	SIZE (")	DESCRIPTION	CTN/QTY	WT/100
336012	12 × 1-3/4	90° Elbow	10	500
336112	12 × 1-3/4	45° Elbow	10	306
336116	12 × 1-3/4	30° Elbow	10	306
336022	12 × 1-3/4	Short Way 90° Elbow	20	210
336114	12 × 1-3/4	Short Way 45° Elbow		190

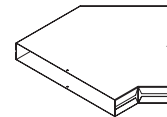

45° Elbow

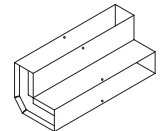

90° Elbow Short Way

WALL DISCHARGES

ITEM #	SIZE (")	DESCRIPTION	CTN/QTY	WT/100
336623	12 × 1-3/4	Wall Discharge with Damper	20	208
336628	12 × 4	Wall Discharge Flat Top with Damper	20	208

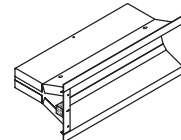

Wall Discharge

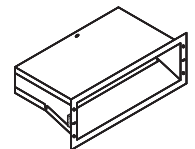

Wall Discharge Flat Top

SOFFIT DISCHARGES

ITEM #	SIZE (")	DESCRIPTION	CTN/QTY	WT/100
336723	12 × 1-3/4	Soffit Discharge 2-1/8" with Damper	20	235
336726	12 × 1-3/4	Soffit Discharge 3-1/4" with Damper	20	260

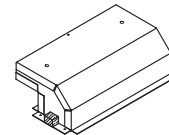

Soffit Discharge

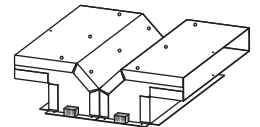

Dual Inlet

DUAL INLETS

ITEM #	SIZE (")	DESCRIPTION	CTN/QTY	WT/100
336832	12 × 1-3/4	Rectangular Dual Inlet – 2-1/8"	*	530
336836	12 × 1-3/4	Rectangular Dual Inlet – 3-1/4"	*	570

ALUMINUM GRILLES

ITEM #	SIZE (")	DESCRIPTION	CTN/QTY	WT/100
703404	12 × 4	Aluminum Grille	*	100
703405	12 × 4	Aluminum Grille with 1/4" Fold	*	100

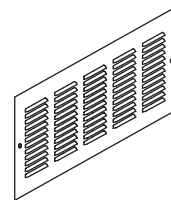

Aluminum Grille

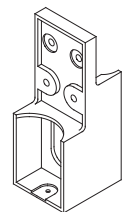

Plastic Support Bracket

SUPPORT BRACKETS

ITEM #	SIZE (")	DESCRIPTION	CTN/QTY	WT/100
703408	3-1/4 – 2-1/8	Plastic Support Brackets	100	11
703409	2-3/4 – 2-1/8	Plastic Support Brackets	100	11

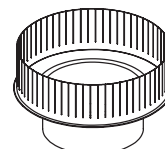

Increaser

INCREASERS

ITEM #	SIZE (")	DESCRIPTION	CTN/QTY	WT/100
136234	4 – 6	Increaser Galvanized	*	32
136236	5 – 6	Increaser Galvanized	*	32

*Product shipped individually.

– E.&O.E. – Subject to Change Without Notice – May Not Be Available At All Locations –

ECCODUCT™ COMPONENTS (cont'd)

MISCELLANEOUS

ITEM #	SIZE (")	DESCRIPTION	CTN/QTY	WT/100
337828	12 × 1-3/4	Coupler	40	72
703403	12 × 4	Discharge Hood with Backdraft Damper – Satin	*	–
703402	12 × 4	Discharge Hood – Aluminum	*	–
337012	12 × 4	Fascia Extension	20	276
702941	36	N-36-175-9-L Nylon Ties	50	200

*Product shipped individually.

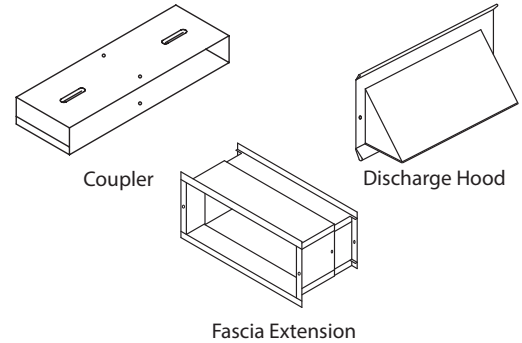

INSULATION

ITEM #	SIZE (")	DESCRIPTION	CTN/QTY	WT/100
706142	48 × 125	DBWEF48125 Reflectix 500 ft/sq ft	*	–

*Product shipped individually.

NOTE: For cold weather climates, this Reflectix DBWEF Insulation in the slab has been shown to be as effective as 4" of foam insulation.



DRYER BOOSTER FAN

ITEM #	DESCRIPTION	CTN/QTY	WT/100
810620	EDB409 Dryer Booster Fan	*	1200

*Product shipped individually.

NOTE: Designed and manufactured to integrate with ECCODUCT™ Dryer Exhaust System.

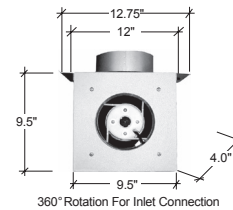

LINT TRAPS — SLIM LINE (PATENTED)

ITEM #	SIZE (")	A (")	Ø B (")	CTN/QTY	WT/100
599704	4 - 5 × 28-1/2	28 -1/2	5	2	600
599706	4 - 5 × 30-1/2	30 -1/2	5	2	610
599707	4 - 4 × 30-1/2	30 -1/2	4	2	610

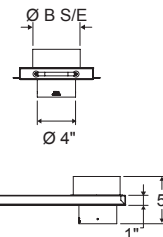
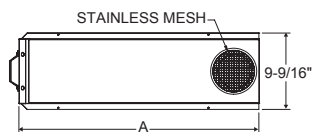

Visit: www.eccoduct.com for additional information.

– E.&O.E. – Subject to Change Without Notice – May Not Be Available At All Locations –



TYPICAL SPECIFICATIONS FOR IN-SLAB DUCT VENTILATION SYSTEM

In-Slab Duct Ventilation shall be ECCODUCT™ system as manufactured by ECCO Manufacturing™.

Ducting shall be manufactured with high quality galvanized steel using spiral wound lockseam with internal reinforcing.

All fittings incased in concrete such as inlet boots, elbows, support brackets, soffit, and wall discharge and spiral wound duct shall have labeled fittings tested to ULC standards.

- The ECCODUCT™ system has a MAX 3-HR F & FT rating tested in accordance with ULC S115-M95 and ASTM E814-02 test requirements.
- Impact loading meeting requirements of CAN3 A23.1 M77, Falsework for Construction Purposes.
- Point loading meeting requirements of CSA S269.1 1975, Falsework for Construction Purposes.
- Airflow and duct friction charts to be provided in accordance with SMACNA and ASHRAE guidelines.

Testing data shall be provided to the engineer prior to installation to ensure the above requirements are met.

In cold weather climates, ECCODUCT™ shall be externally wrapped with Reflectix DBWEF Duct Insulation on the exterior envelope discharges and intakes. Insulation distance to comply with local codes.

Installation shall be completed as per "ECCODUCT™ Installation Procedures", as provided by ECCO Manufacturing™. Non compliance may result in impeded performance for which ECCO™ does not assume responsibility.

All testing performed by Intertek Testing Services NA Ltd., Warnock Hersey and Hardy Associates Ltd.

The ECCODUCT™ system can be used for supply and/or exhaust as well as for clothes dryer exhaust.

For clothes dryers the following design criteria should be considered:

- Use of an approved dryer booster fan.
- Use of an external lint trap.
- All duct joints to be taped using an elastomeric tape approved by the engineer.
- A regular maintenance schedule for the dryer ducts should be established by the building owner in conjunction with a professional duct cleaning service.

DISCLAIMER

ECCO™ is providing no representations or warranties whatsoever in respect of the **ECCO™** product described herein, whether statutory, expressed or implied by custom or industry practice or otherwise. **ECCO's** only liability to the customer will be to repair or replace product which is demonstrated in a timely way to have observable manufacturing defects and in any case **ECCO's** liability shall not exceed the value of the goods being sold.

ECCO™ accepts no responsibility for installation, design or operating deficiencies or problems (including moisture leakage) associated with the product. The customer and any person responsible for installation and operation of our products should ensure that a building contractor, architect and/or engineer be consulted to ensure product is appropriate for, and installation and operation accords to, applicable building codes and prudent installation practices and are consistent with building design and construction, including building envelope.



www.eccomfg.com

Langley Distribution

19860 Fraser Highway
Langley, British Columbia
Canada V3A 4C9

Phone: 604-530-4151
Toll Free: 1-877-955-4805
Fax: 604-533-9335

Calgary Distribution

21 – 11150 38th Street, S.E.
Calgary, Alberta
Canada T2C 2Z6

Phone: 403-720-0895
Toll Free: 1-877-955-4815
Fax: 403-720-0897

Kent Distribution

20001 87th Ave. S, Bldg E
Kent, Washington
USA 98031

Phone: 253-872-3721
Toll Free: 1-800-207-6859
Fax: 253-872-3724